

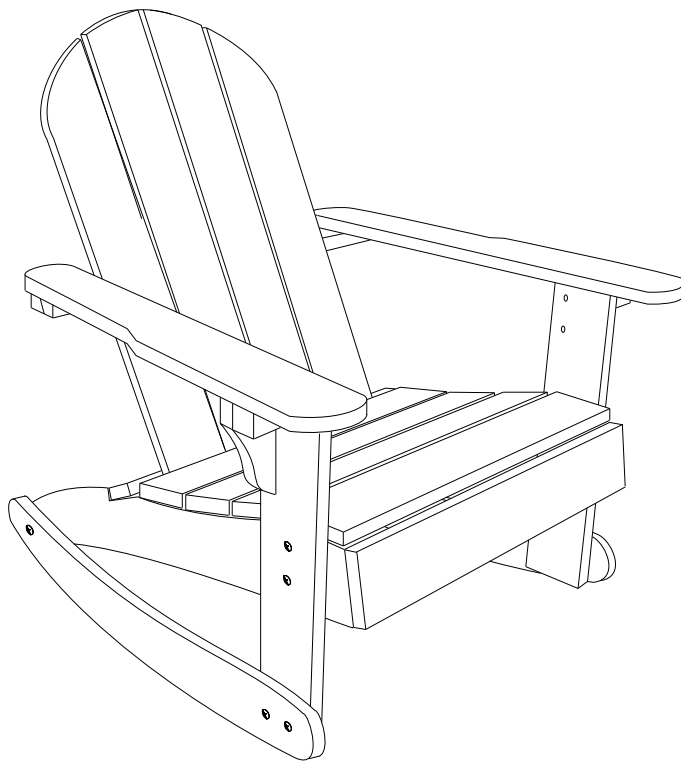

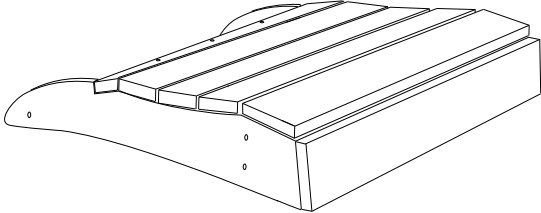

JO-ANN STORES INC

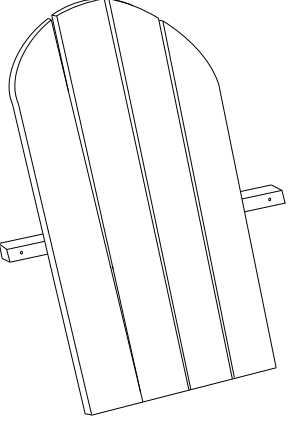
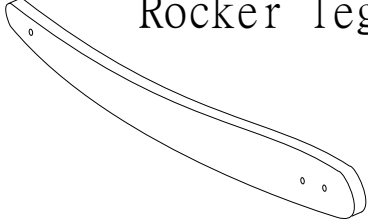
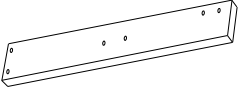
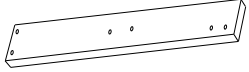
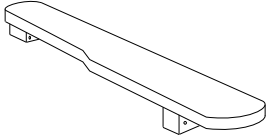
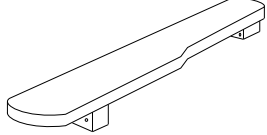
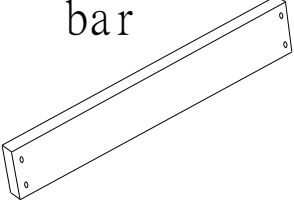

Article 193-4280
Child Wooden Rocking Chair

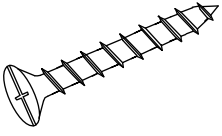
CUSTOMER SERVICE NUMBER: 1-888-857-3862
www.goodsupport.com

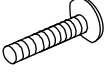
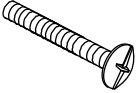
<p>A Rocker seat</p>  <p>1 PC</p>	<p>B Rocker back</p>  <p>1 PC</p>	
<p>C Rocker legs</p>  <p>2 PCS</p>	<p>D1 Support bar</p>  <p>1 PC</p>	
<p>D2 Support bar</p>  <p>1 PC</p>	<p>E Rocker arm</p>  <p>1 PC</p>	<p>F Rocker arm</p>  <p>1 PC</p>
<p>G Connection bar</p>  <p>1 PC</p>	<p>(1) Support block</p>  <p>2 PCS</p>	<p>(2) Screws</p>  <p>11 PCS</p>
<p>(3) Nuts</p>  <p>14 PCS</p>	<p>(4) Screws</p>  <p>10 PCS</p>	<p>(5) Screws</p>  <p>4 PCS</p>

STEP 1

1. Attach support (D1) and (D2) to rocker seat (A) using nuts (3) and screws (4) as shown.
2. Attach connection bar (G) to rocker seat (A) using screws (2) as shown.

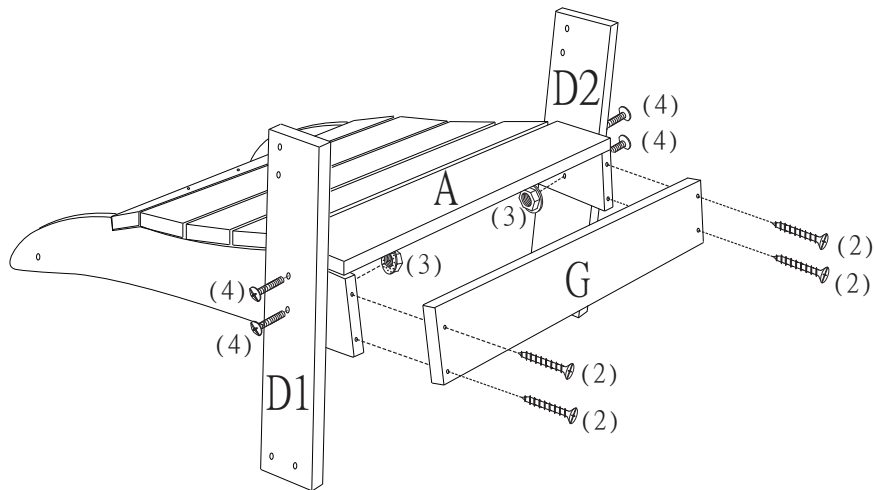

STEP 2

1. Attach rocker legs (C) to rocker seat (A) using nuts (3) and screws (4) as shown.
2. Attach support block (1) to support bar (D1) and (D2) using screws (2) as shown.

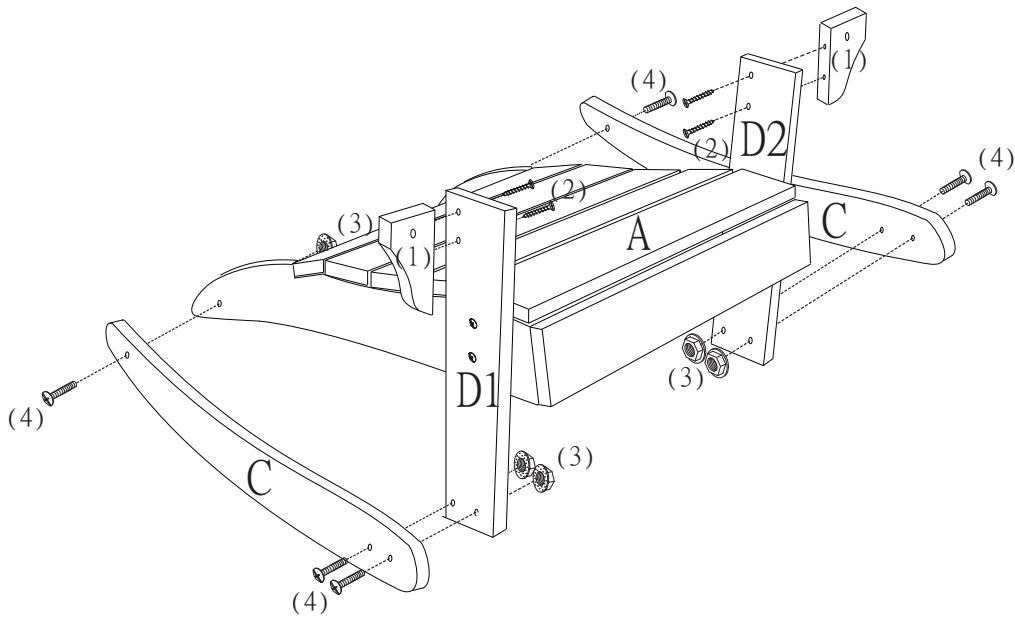

STEP 3

1. Attach rocker back (B) to rocker seat (A) using screws (2) as shown.
2. Attach left rocker arm (E) to rocker back (B) and support block (1) using nuts (3) and screws (5) as shown.
3. Attach right rocker arm (F) to rocker back (B) and support block (1) using nuts (3) and screws (5) as shown.

