

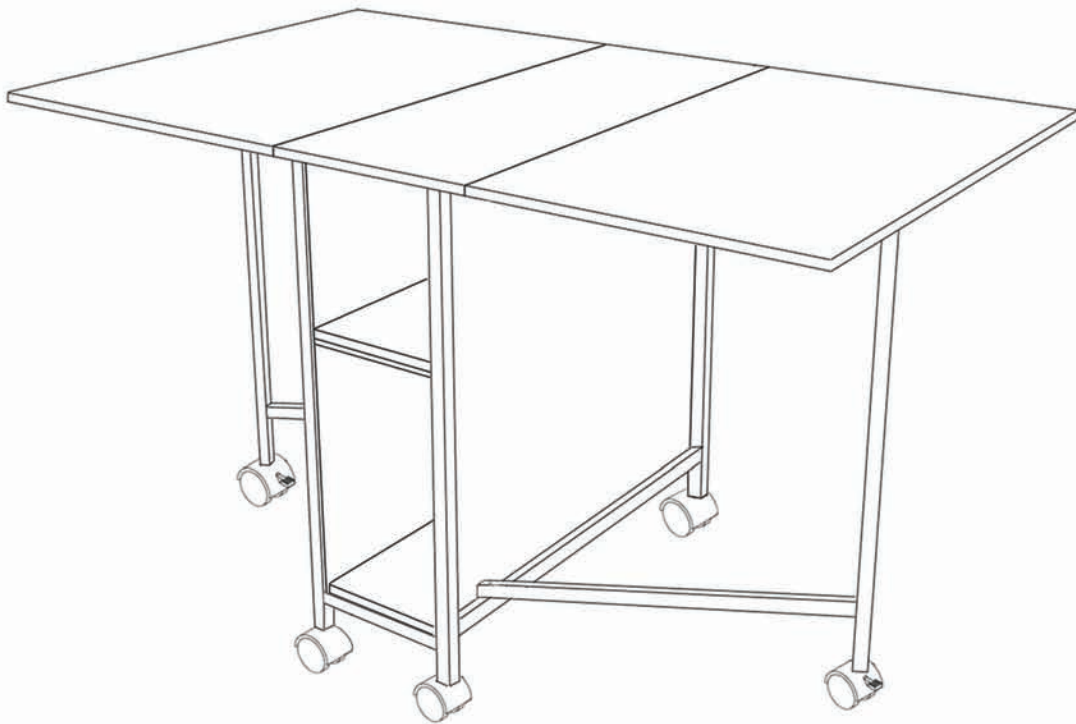

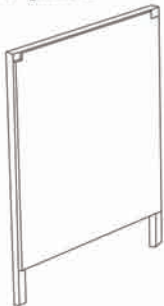

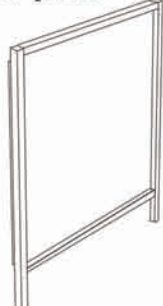







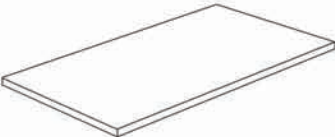
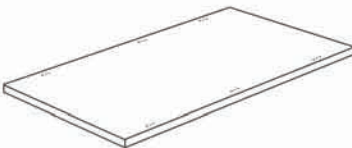
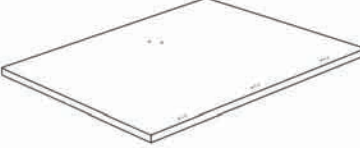

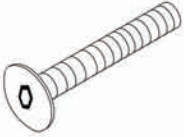

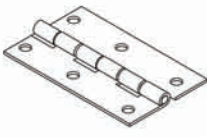
JO-ANN STORES INC

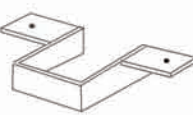

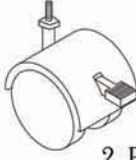
Article#9733635
SEW ESSENTIALS CUTTING TABLE

CUSTOMER SERVICE NUMBER: 1-888-857-3862

<p>A1 Left panel</p>  <p>1 PC</p>	<p>A2 Right panel</p>  <p>1 PC</p>	<p>B Connecting bar</p>  <p>25x25x315mm 4 PCS</p>		
<p>C Horizontal bar for pivoting legs</p>  <p>25x25x566mm 4 PCS</p>	<p>D Upright bar for pivoting legs</p>  <p>25x25x815mm 2 PCS</p>	<p>E Shelf</p>  <p>2 PCS</p>		
<p>F Top Middle board</p>  <p>1 PC</p>	<p>G Top Side board</p>  <p>2 PCS</p>	<p>H Supporting bar</p>  <p>∅12x304mm 3 PCS</p>		
<p>(1) Screws</p>  <p>∅6x43mm 22 PCS</p>	<p>(2) Screws</p>  <p>∅4.5x34.5mm 10 PCS</p>	<p>(3) Hinges</p>  <p>6 PCS</p>		
<p>(4) Screws</p>  <p>∅3.5x13.5mm 40 PCS</p>	<p>(5) Screws</p>  <p>∅4.2x22mm 3 PCS</p>	<p>(6) Stopper</p>  <p>2 PCS</p>	<p>(7) Wheel</p>  <p>4 PCS</p>	
<p>(8) Locking Wheel</p>  <p>2 PCS</p>	<p>(9) Tool</p>  <p>1 PC</p>	<p>(10) Wrench Tool</p>  <p>1 PC</p>	<p>(11) Gasket</p>  <p>6 PCS</p>	<p>(12) Gasket</p>  <p>8 PCS</p>

STEP 1 Attach connecting bar (B) and supporting bar (H) to Left panel (A1) and right panel (A2) using screws (1) and tool (9) as shown.

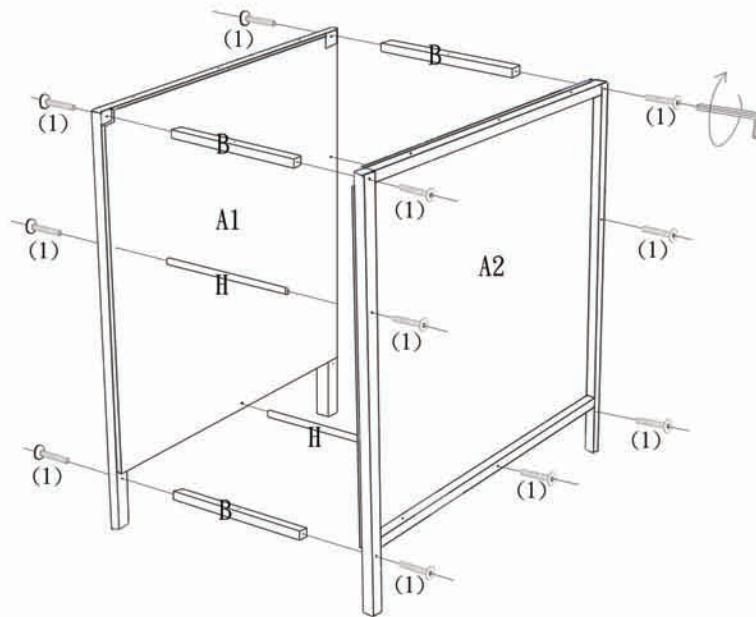

STEP 2 1. Attach wheel (7) to left panel (A1) and right panel (A2) using wrench tool (10) and gasket (11) as shown.
2. Attach top middle board(F)to left panel(A1),right panel (A2) and supporting bar (B) using screws (2) as shown.

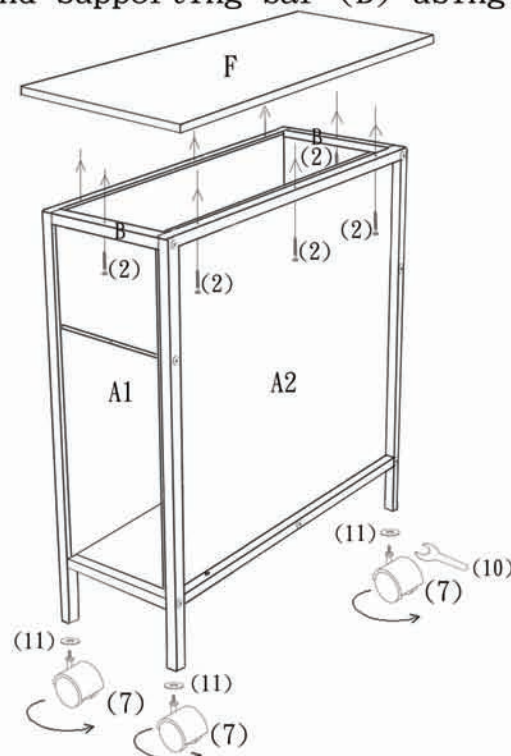

- STEP 3**
1. Put shelf (E) to supporting bar using screws (5) and screws (2) as shown.
 2. Attach horizontal bar (C) to upright bar (D) and main body using screws (1), gasket (12) and tool (9) as shown.

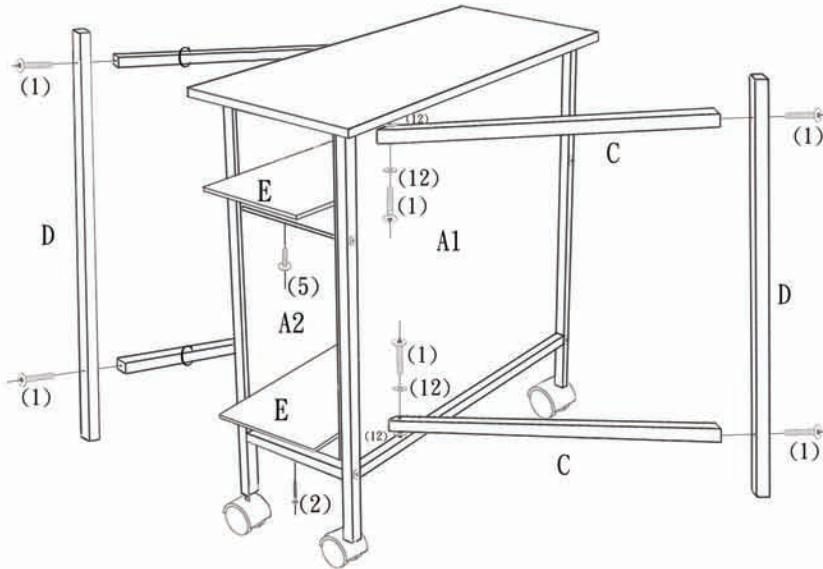

- STEP 4**
1. Attach locking wheel (8) to upright bar for pivoting legs (D) using wrench tool (10) and gasket (11) as shown.

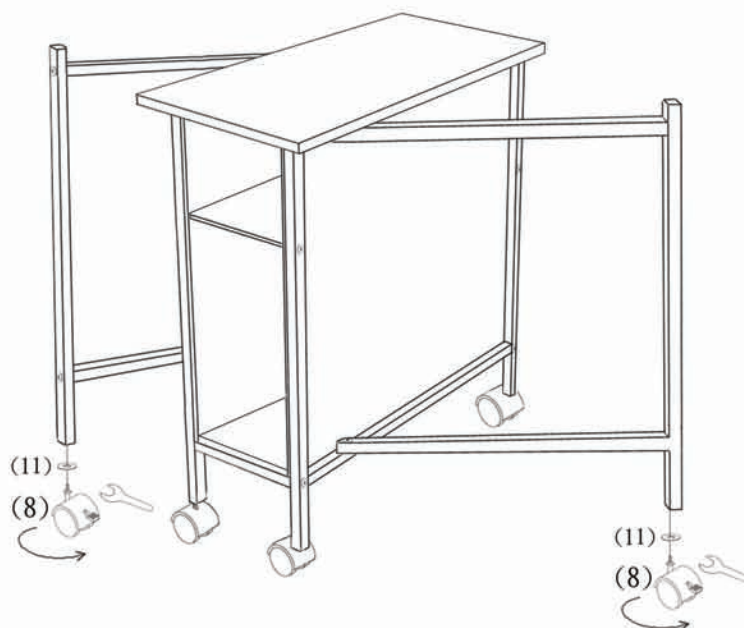

- STEP 5**
1. Attaching stopper (6) to top side board (G) using screws(4) as shown.
 2. Attach top side (G) to top middle board (F) using screws(4) and hinges (3) as shown.

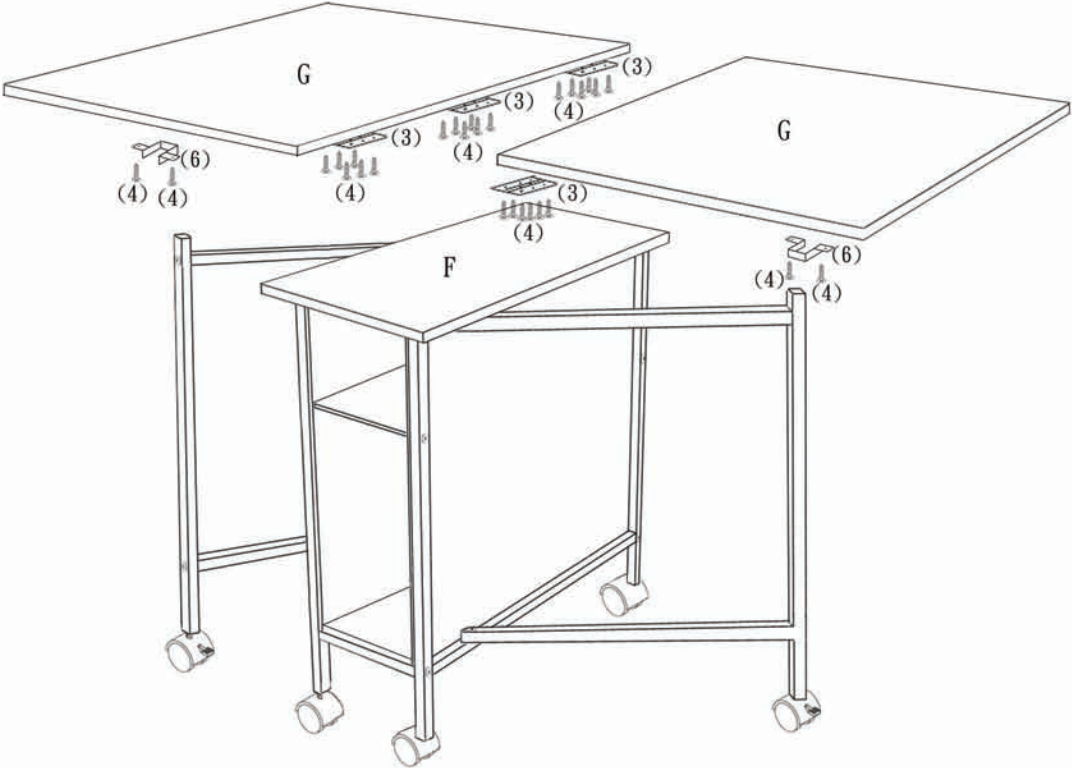

Completed

